

Committed to Providing Quality Products
with the Best Service

Uflow[®]
Automation
INDIA

Automation
Simplified...



Solenoid Valve

Angle Seat Valve

Rotary Coupling

Pneumatic Directional Control Valve

Actuator

Cylinder

One Touch Fitting

Ball Valve

Butterfly Valve



Country of Origin - INDIA



COMPANY PROFILE

Uflow Automation is an engineering organization committed to provide complete solutions to customer's requirements. We are established in the year 2007 and progressing with a vision of applying finest engineering practices in valve manufacturing industry by our restless and high skilled **ENGINEERS**, standard organizational **PROCESSES** and superior quality **PRODUCTS**.

We are leading in solenoid valve manufacturing company in India, Know as **UFLOW** our range of products include - Pilot Operated Diaphragm Type Valves, Pneumatically Control Valves, Gas Solenoid valves, High Pressure Valves, Industrial Valves, Pneumatic Directional Control Valves, Rotary Coupling and Actuators. Our products are sold across INDIA and being exported outside India in various other countries.

Our Quality	Our Commitment	About Us
<ul style="list-style-type: none"> <input checked="" type="checkbox"/> In-House full scale testing facility. <input checked="" type="checkbox"/> Lean manufacturing practices / six sigma, kaizen, 5S. <input checked="" type="checkbox"/> Certified by : ISO 9001:2015 (TUV Nord), CE, ERDA, CIMFR, BIS, PESO. 	<ul style="list-style-type: none"> <input checked="" type="checkbox"/> To understand customer's need first before proposing our products. <input checked="" type="checkbox"/> To keep on providing competitive rate's by adapting to continuous process improvement, without compromising on quality. <input checked="" type="checkbox"/> To provide continuous support to our customers and go beyond their expectations in terms of delivery and after sale services. 	<ul style="list-style-type: none"> <input checked="" type="checkbox"/> In house R&D, manufacturing and testing facility is all located in a single premise at Rajkot Gujarat India. <input checked="" type="checkbox"/> Authorized channel partners in 20 different states in India. <input checked="" type="checkbox"/> Sales office in the UAE, Germany, Chile, Australia (Expanding).

We started building our products for a specific market segment and over the period of time we progressed to built it for various sectors that includes:

- | | | | | | |
|---|---|--|---|--|--|
| <input checked="" type="checkbox"/> Textile | <input checked="" type="checkbox"/> Water Treatment | <input checked="" type="checkbox"/> Energy & Power | <input checked="" type="checkbox"/> Packaging | <input checked="" type="checkbox"/> Pharmaceutical | <input checked="" type="checkbox"/> Oil & Gas |
| <input checked="" type="checkbox"/> Nuclear | <input checked="" type="checkbox"/> Marine | <input checked="" type="checkbox"/> Chemical | <input checked="" type="checkbox"/> Food and Beverage | <input checked="" type="checkbox"/> Steel & Cement | <input checked="" type="checkbox"/> Automotive |

We stand amongst the pioneers of the industry because of our following competitive advantages:

- Total quality management allow us to maintain the quality of our products,
- We follow genuine customer relationship policy and that help us to build trusted relationships.
- We believe in timely delivery and consistent quality standard, and this is possible due to the state of the art testing facility, that ensures our customers don't have any complains.
- Innovative products range with sophisticated and latest technology.
- Qualified customer service team, facilitate with the customers to resolve their respective query. Also feel free to ask for our customer references and product samples.

Uflow's Quality control is based on the platform of stringent process control by elimination of production variances; by a computerized integrated system we are able to guarantee the quality of products, and by recording each production step to ensure effective data analysis as well as a complete and efficient traceability of both components and finished products. This practice helps us in maintaining standards of high competitiveness in the marketplace.

Note: *For Any Other Information Contact Uflow.
* All Information may change without prior notice.



**BUTTERFLY VALVE
SERIES**

Specifications

End Connection :	Lug
Range :	DN50 - DN150
Suitable :	ASMI B16.5 150#
Pressure Range :	PN10, PN16
Leakage Class :	100% Tightness at fully differential pressure
Standard :	API 609, BS 5155, ISO 5211, API 598, ASME B16.5
Body Material :	Cast Iron(CI), SGI, WCB, CF8, CF8M
Disc Material :	SGI, CF8, CF8M, WCB
Stem Material :	SS410, SS304, SS316
Body Liner / Seat Material :	NBR, EPDM, VITON, SILICONE, PTFE
Shaft Bearing Material :	PTFE

Features

- ☑ Bi-directional zero leakage butterfly valve.
- ☑ ISO Pad for mounting, Gear Operator / Actuator
- ☑ Extremely small play between the stem and disc due to 'Double D' drive.
- ☑ Accurate dual stem sealing prevents leakage.
- ☑ Standard flanged drilling : PN10/PN16, JIS 10K/16K, ASME 125/150#
- ☑ 100% Tested With Pneumatic And Fluid (Water) Media.
- ☑ Design Standard : ISO 5211, API 609, ASME B16.5 150#.
- ☑ Face to Face Dimension : API 609 (CAT A).
- ☑ Operator mounting flange : As per ISO 5211.
- ☑ Operator : Hand Lever / Gear / Actuator
- ☑ Leakage Class : 100% tightness at full differential Pressure.

Hand Lever Operated Lug Type Butterfly Valve

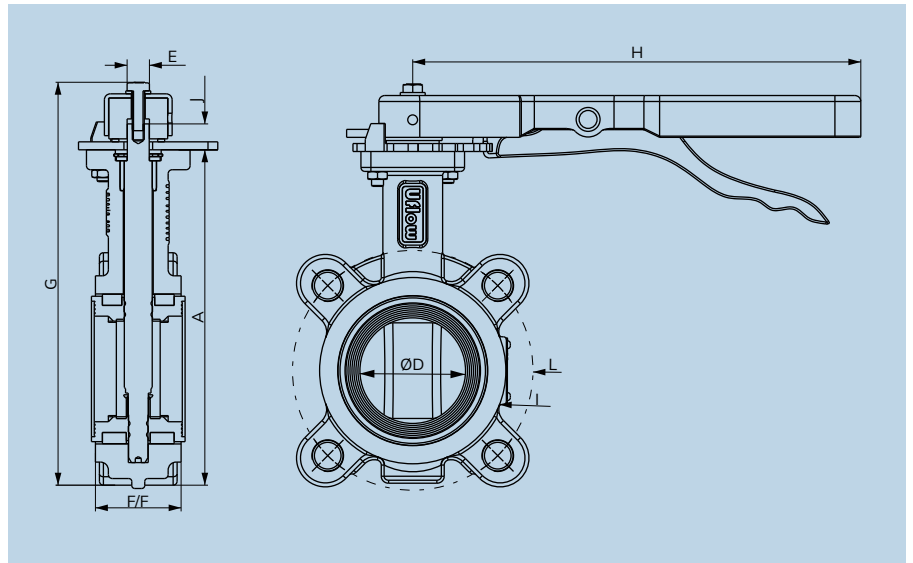

Technical Data (All dimensions are in mm)

All dimensions are approx.

Size	A	ØD	F/F	ØI	ØL	G	J	H	E	MOUNTING FLANGE
50 MM	168	53	43	93	120	202	13	225	11	F05
65 MM	191	66	46	105	140	224	12	225	11	F05
80 MM	214	80	46	126	152.5	248	14	225	11	F05
100 MM	258	104	52	150	190.5	289	17	260	14	F07
125 MM	287	125	56	175	216	320	20	260	17	F07
150 MM	318	150	56	203	241	350	19	260	17	F07

Pneumatic Operated Lug Type Butterfly Valve - PN10

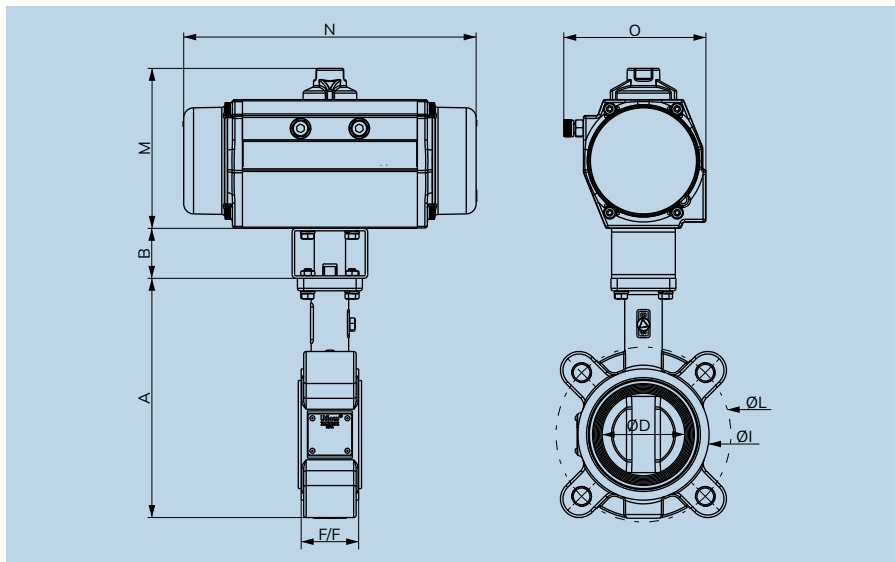

Technical Data - Butterfly Valve with Double Acting Actuator (All dimensions are in mm)

All dimensions are approx.

Size	Actuator	Coupler	A	B	ØD	F/F	ØI	ØL	M	N	O	Mounting Flange
50 MM	50	NA	168	-	53	43	93	120	99	125	85	F05
65 MM	50	NA	191	-	66	46	105	140	99	125	85	F05
80 MM	50	NA	214	-	80	46	126	152.5	99	125	85	F05
100 MM	63	NA	258	-	104	52	150	190.5	112	147	105	F07
125 MM	80	NA	287	-	125	56	175	216	128	170	114	F07
150 MM	80	NA	318	-	150	56	203	241	128	170	114	F07

Technical Data - Butterfly Valve with Single Acting Actuator (All dimensions are in mm)

All dimensions are approx.

Size	Actuator	Coupler	A	B	ØD	F/F	ØI	ØL	M	N	O	Mounting Flange
50 MM	50	NA	168	-	53	43	93	120	99	162	84.9	F05
65 MM	63	C1455V0	191	60	66	46	105	140	112	202	105	F05
80 MM	80	C1755V0	214	40	80	46	126	152.5	128	294	114	F05
100 MM	100	C4277V0	258	40	104	52	150	190.5	153	324	145	F07
125 MM	100	C7277V0	287	40	125	56	175	216	157	324	145	F07
150 MM	125	C7270V0	318	61	150	56	203	241	185	389	173	F10

Pneumatic Operated Lug Type Butterfly Valve - PN16

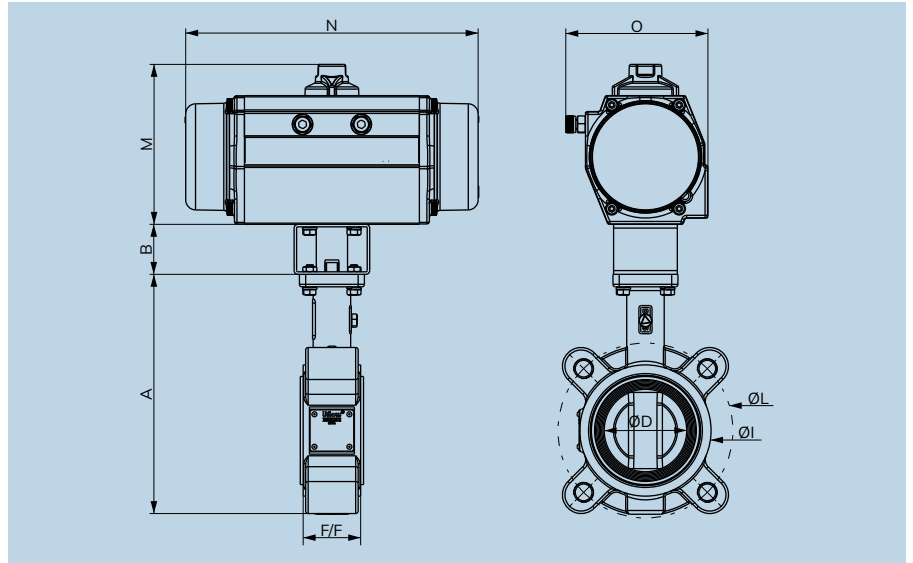

Technical Data - Butterfly Valve with Double Acting Actuator (All dimensions are in mm)

All dimensions are approx.

Size	Actuator	Coupler	A	B	ØD	F/F	ØI	ØL	M	N	O	Mounting Flange
50 MM	50	NA	168	-	53	43	93	120	99	125	85	F05
65 MM	50	NA	191	-	66	46	105	140	99	125	85	F05
80 MM	63	C1455V0	214	60	80	46	126	152.5	99	147	91	F05
100 MM	80	C4777V0	258	40	104	52	150	190.5	112	170	105	F07
125 MM	80	NA	287	-	125	56	175	216	128	170	114	F07
150 MM	100	C7277V0	318	40	150	56	203	241	128	220	114	F07

Technical Data - Butterfly Valve with Single Acting Actuator (All dimension are in mm)

All dimensions are approx.

Size	Actuator	Coupler	A	B	ØD	F/F	ØI	ØL	M	N	O	Mounting Flange
50 MM	80	C1755V0	168	40	53	43	91	120	128	234	114	F05
65 MM	80	C1755V0	191	40	66	46	97	140	128	234	114	F05
80 MM	100	C1257V0	214	40	80	46	117	152.5	153.5	324	145	F05
100 MM	100	C4277V0	258	40	104	52	149	190.5	153.5	324	145	F07
125 MM	125	C7277V0	287	40	125	56	169	216	185	389	173	F07

Gear Box Operated Lug Type Butterfly Valve

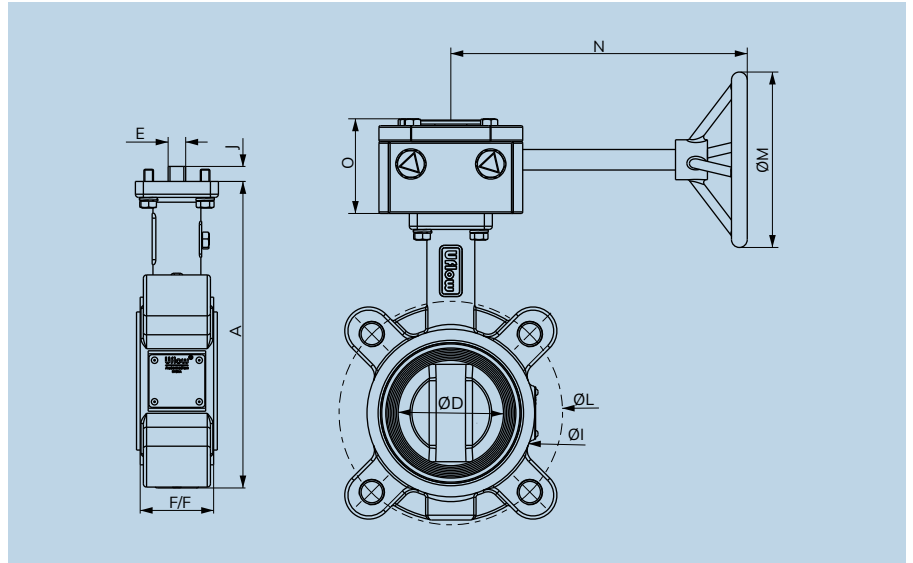

Technical Data (All dimensions are in mm)

All dimensions are approx.

Size	A	D	F/F	ØI	ØL	E	J	ØM	N	O	Mounting Flange
50 MM	168	53	43	93	120	11	13	175	203	48	F05
65 MM	191	66	46	105	140	11	12	175	203	48	F05
80 MM	214	80	46	126	152.5	11	14	175	203	48	F05
100 MM	258	104	52	150	190.5	14	17	175	203	48	F07
125 MM	287	125	56	175	216	17	20	175	203	48	F07
150 MM	318	150	56	203	241	17	19	175	203	48	F07

FULL LUG AND FLANGE END BUTTERFLY VALVE MODEL IDENTIFICATION CHART

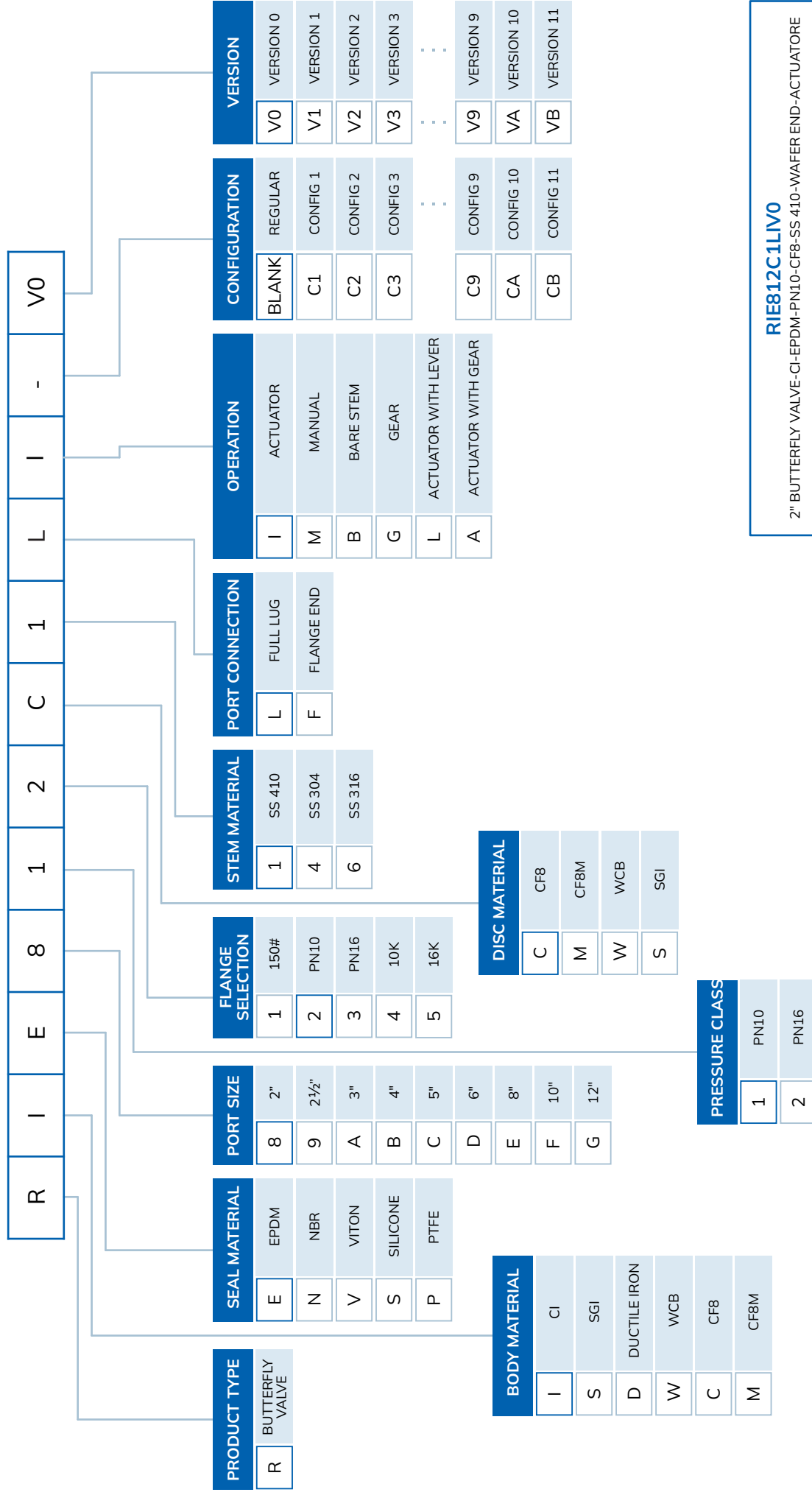

RIE812C11V0

2" BUTTERFLY VALVE-CI-EPDM-PN10-CF8-SS 410-WAFER END-ACTUATORE

Our Clients



Global Presence...



Made In India



CONTACT US:

✉ sales@uflowvalve.com ☎ +91 89059 07070 📞 +91-2827-254343 🌐 www.uflowvalve.com

📍 Uflow Automation, Ankur Industrial Complex, Sur vey No: 275/276, Plot No: 31, Nr. Intol Cast Pvt. Ltd. Shapar(Veraval) Dist.: Gujarat (India) - 360 024.