

2/2 WAY DIRECT ACTING AUTO DRAIN SOLENOID VALVE

Automation
Simplified...



Solenoid Valve

Angle Seat Valve

Rotary Coupling

Pneumatic Directional Control Valve

Actuator

Cylinder

One Touch Fitting

Ball Valve

Butterfly Valve

Country of Origin - INDIA

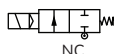

Specifications

Port :	½" - BSP Thread			
End Connection :	Screwed			
Body Material :	CF8			
Diaphragm :	Nitrile (NBR)	EPDM	Viton (FKM)	SPL. Viton
Media Temp :	-30°C to 90°C	-10°C to 140°C	-10°C to 180°C	-10°C to 180°C
Circumstance Temp :	-10°C to 70°C			
Media :	Air, Water, Chemical, Gas			
Main Features :	Internal Parts are in superior corrosion resistance steel			

Operating Voltage :	230AC
Power Consumption :	9W
Coil Features :	High Reliability Unaffected by Voltage Surges. Easy coil changes coil lockable in 4X90 position or freely movable in between as require.
Coil Housing :	IP65 Epoxy square coil
Timing :	Cycle : 1 min to 120 min Adjustable Drain : 1 sec to 25 sec Adjustable

Features

- Designed specially to drain sludge and rust laden condensate
- Reliable all digital electronic circuitry
- ON and OFF timing adjustable

Technical Data

Valve Model No.	Timer Model No.	Body Material	Pipe (Inch)	Orifice (mm)	Min. Operating Pressure Kg/cm ²	Max. Operating Pressure Kg/cm ²	Seal & Diaphragm Material	Flow Factor Kv m ³ / hr
ACN205BNEW015V0	T11ANV0	CF8	½"	1.5	0	16	NBR / EPDM / Viton / SPL. Viton	0.07
ACN205BNEW030V0	T11ANV0	CF8	½"	3	0	16	NBR / EPDM / Viton / SPL. Viton	0.20

DIMENSIONS (MM)

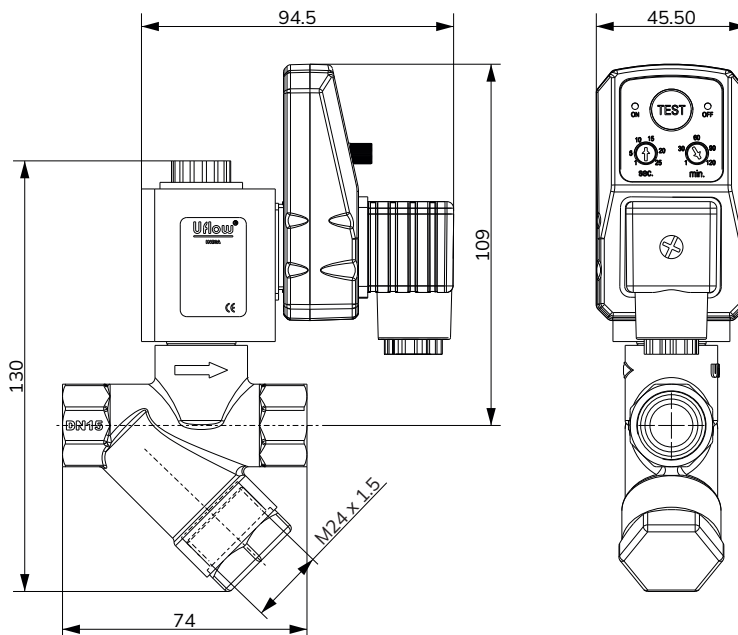

* All dimensions are approx

2 WAY DIRECT ACTING AUTO DRAIN MODEL IDENTIFICATION CHART

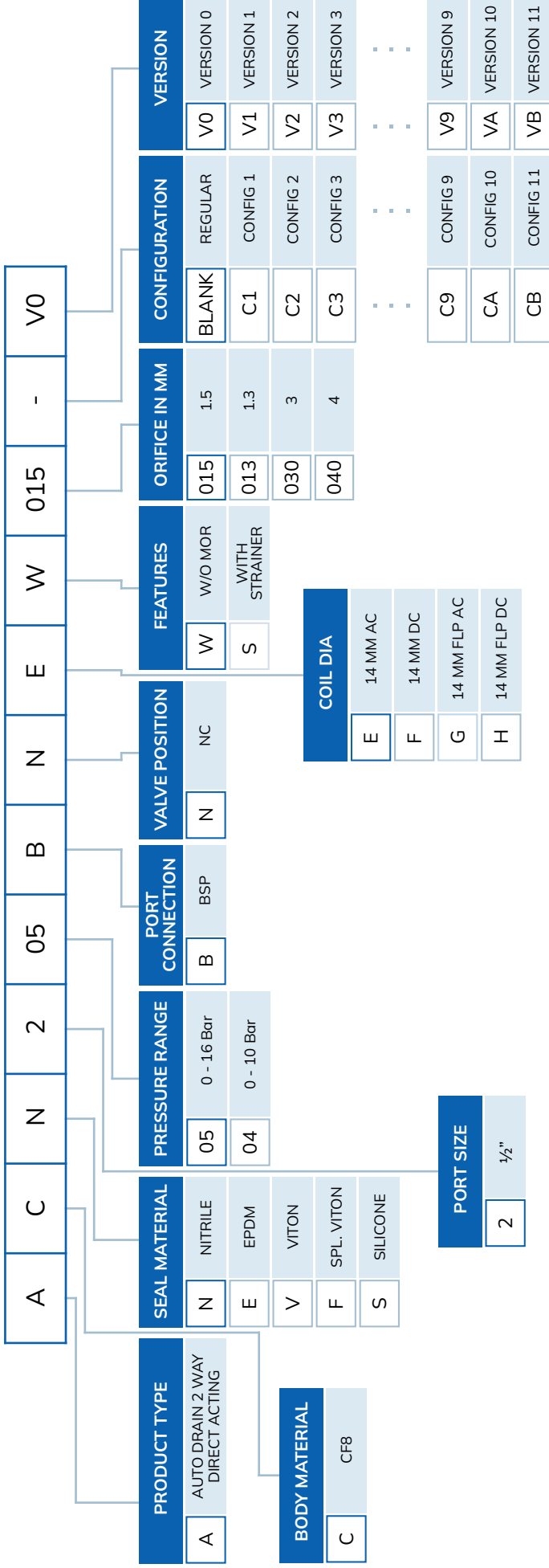

ACN205BNEW015V0
 1/2" AUTO DRAIN 2 WAY DIRECT ACTING CF8-NITRILE-0 TO 16 Bar-BSP-NC-14MM AC-1.5MM ORIFICE

Note: The above chart is for identification purposes only, and it may not be possible to make all combinations for the above chart.

TIMER MODEL IDENTIFICATION CHART

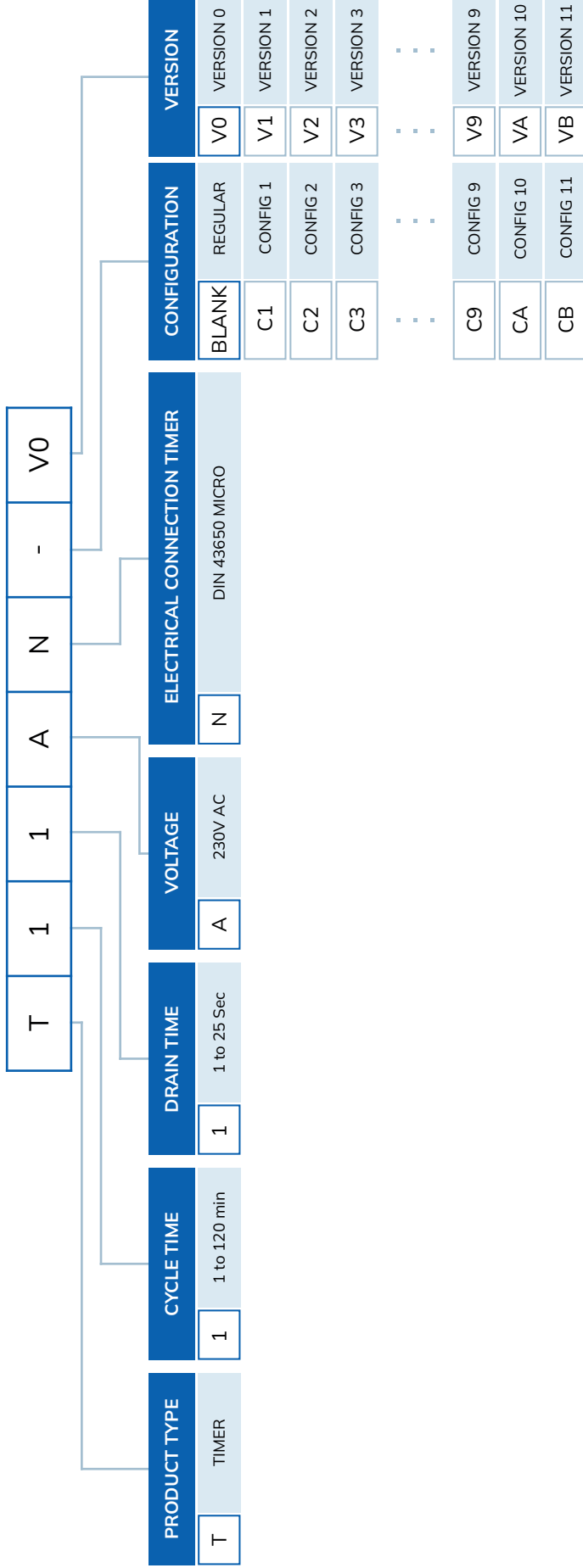

T11ANVO
 TIMER 1 TO 120 MIN-1TO 25 SEC-230V AC-DIN 43650 MICRO

Note : The above chart is for identification purposes only, and it may not be possible to make all combinations for the above chart.

Global Presence...



Made In India



CONTACT US:

✉ sales@uflowvalve.com ☎ +91 851 109 8822 🌐 www.uflowvalve.com

📍 Uflow Automation, Ankur Industrial Complex, Survey No: 275/276, Plot No: 31, Nr. Intol Cast Pvt. Ltd. Shapar(Veraval) Dist.: Gujarat (India) - 360 024.